



SMBW mini 240

>> SERVO IGBT DRIVE

MAIN FEATURES:

- Dual 32 bit DSP design, Embedded Motion controller with servo drive
- Multi functionality: Torque mode, Speed mode, Position mode, Smart Point to Point
- 100us sampling rate & calculation loop
- 1 Mbit/sec, High speed pulse command input (A/B phase, CW/CCW, CK/DIR)
- 8 pre fixed digital input
- Simulation encoder Output: adjustable
- 4 digital output (S ready, S alarm, Pos complete, Arrester release)
- Analog input 2ch, 16 bit resolution
- RS 232, 9600 – 115000 Kbs – RS 485 MOD BUS
- Position control mode, 16 length position data selectable
- Sinusoidal acceleration and deceleration velocity profile
- Monitor software
- CAN Open option available



Professional
Power Transmission

CONNECTORS:

- 10126-3000PE 26 pins IEEE-488 - 3M
- 10136-3000PE 36 pins IEEE-488 - 3M
- D-Sub Female 9 pins (RS232)

PLASTIC COVERS:

- 10326-52 F0-008 (for 26 pins connector)
- 10336-52 F0-008 (for 36 pins connector)

Output current (Amp)	4 A Continuous	8 A Peak
Drive range	Brushless servomotors up to 750W	
Power Input	Single/Three-Phase 220V AC, 50/60Hz	
Power Output	Three-Phase 0 Input power votage	
Sinusoidal PWM	IGBT Sinusoidal Pulse-Width-Modulation (10Khz)	
Encoder Type	Incremental	
Control mode	Torque, Speed, Position control modes & Embedded motion profiles	
Modes:	P-Command mode	1. Pulse input: A/B phase, CW/CCW or Clock/Direction 500kHz 2. Bit rate: 1M bps 3. Gear ratio: 50000 1/50000
	Position control mode	1. 16 independent position length 2. 16 selectable speed / torque /acc /dec profiles 3. Mixed 4. Metric number system 5. Multi mode home search
	Speed control mode	1. Control range 30000 : 1 2. Preset Speed, by 3-bits DIX 3. 4 torque limit setting, by 2-bits DIX
	Torque control mode	Settable Speed Droop range
Encoder	Simulated output Fixed frequency	
Control power	External ac 220V power supply	
Digital input DI(x)	8 standard predefined photo isolated input	
Digital output DO(x)	4 standard predefined photo isolated output (Servo ready, Servo alarm, Position compete, Arrester release).	
Analog input	16 bit resolution A/D inputs: AI1 & AI2 – 2.5Khz sampling rate	
Analog output	Torque / Speed	
Communication	RS-232	
Environment:	Temperature	0 – 50°C
	Humidity	85% RH
	Vibration	0.5G

DIMENSIONS

mm

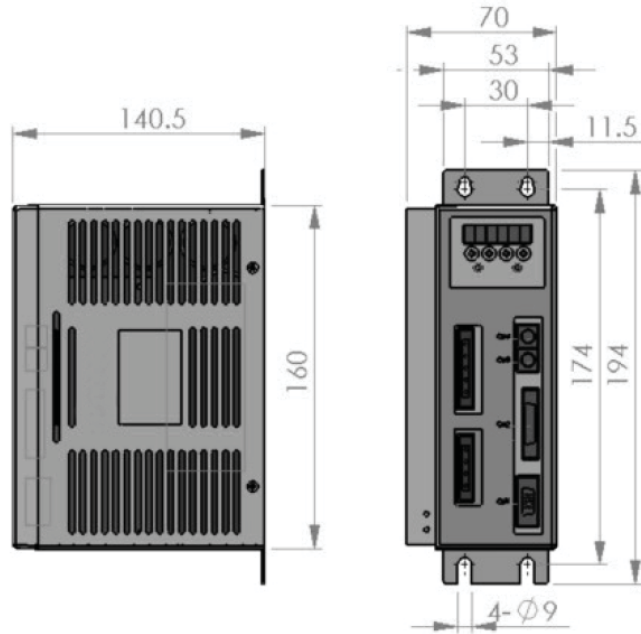

SOFTWARE MOTION VIEW

